



**3-PHASES**

**AVAILABLE IN 480 V**

**AVAILABLE IN 60 Hz**

**AVAILABLE IN  
RIGHT VERSION  
GRT10**



**RASOR**®

1946

# **GRT10L**

## **ELECTRIC 3-PHASES CUTTING UNIT**

**GRT10L. Professional cutting unit for continuous cutting processes in Textile & Technical Textile applications.**



# ELECTRIC 3-PHASES CUTTING UNIT GRT10L



## WHAT'S NEW:

- Low-friction Teflon coated foot
- Easy fixing structure for O.E.M. applications
- Maintenance-free industrial motor
- New sharpening device

**AVAILABLE IN 480 V**  
**AVAILABLE IN 60 Hz**

## TECHNICAL DETAILS:

- Blade diameter:** 100 mm (4"), with hard metal counterblade
- Blade equipped:** 10EHSS, 6-edges, HSS steel
- Blade speed:** 550 r.p.m.
- Cutting ability:** up to 35 mm (1.4")
- Motor:** 3phases asynchronous 380/400V, 50 Hz
- Power:** 75 W
- Max. absorption:** 0.36 A
- Protection:** IP20 - CL F
- Net weight:** 2800 g (with power supply cord)
- Total weight (with packing box):** 4000 g
- Electric cable length:** 1.5 mt (with no plug)
- Minimum brightness for working operations:** LUX 200
- Vibrations at start up:** < 2.5 m/sec<sup>2</sup>
- Temperature range:** 0 – 55 C
- Umidity range:** 10 – 95% without condensate

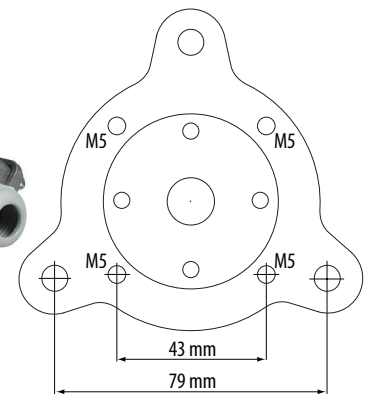
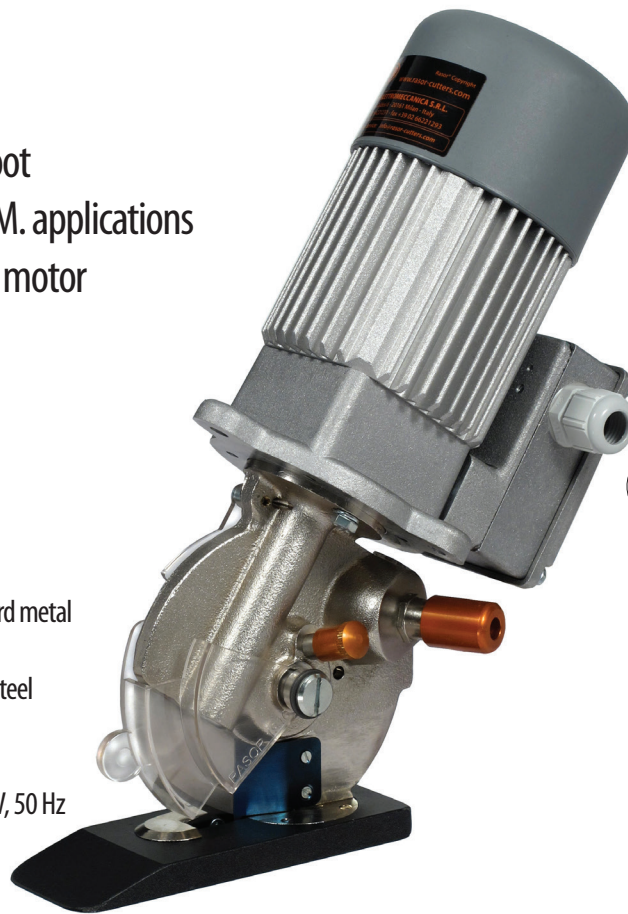

Fixing layout

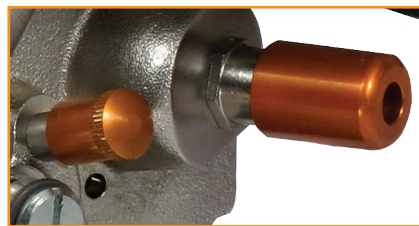

Sharpening device

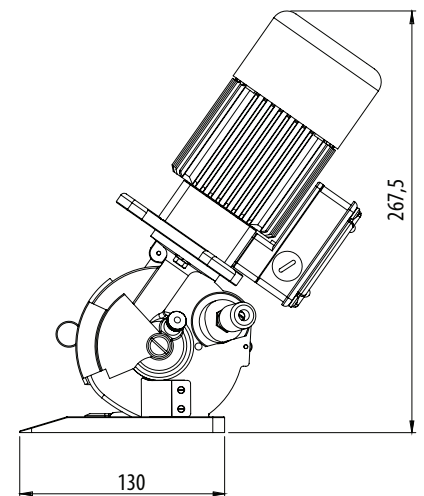

Dimension layout

## BLADES AVAILABLE:

**10EHSS**, 100 mm 6-edges, HSS steel | **10SEXTG**, 100 mm 4-edges, EXTRA steel | **10CSW**, 100 mm circular, HSS steel | **10EHSSTF**, 100 mm 6-edges, HSS steel Teflon® coated | **10EMD**, 100 mm 6-edges, Carbide (Widia®)



PETRONI SRL  
Via A.Bucchi, 1/B  
06012 Città di Castello (PG)  
+39 075/852.07.87  
[www.petronisrl.it](http://www.petronisrl.it)